



2-card, 4-card, and 6-card chassis



21-card chassis

Features and Benefits

- Extend KVM workstations and computers
 - Up to 460 ft (140 m) using CATx cable
 - Up to 3,300 ft (1 km) using multi-mode fiber
 - Up to 33,000 ft (10 km) using single-mode fiber
- Multiple chassis sizes satisfy both large and small system configurations
- Use USB keyboard, mouse, touchscreen, and most HID devices or use option cards to add printers, scanners, hard drives, memory sticks, audio devices, and others
- Video interfaces available:
 - Single-link DVI-D video up to 1920×1200@60Hz
 - DVI-I (VGA) video up to 1920×1200@60Hz with optional scaling
 - HDMI video up to 4K@60Hz
 - DP video up to 4K@60Hz
 - Dual-head DP video on a single CATx or fiber up to 1920×1200@60Hz per channel
 - JPEG XS codec models can extend 5K/4K@60Hz
- Add-on option cards available:
 - 2x USB HID
 - 4x USB 2.0, up to 50/100 Mbps
 - PS/2, RS-232/RS-422 up to 115.2K baud
 - Analog stereo microphone and speaker
 - Digital audio with embedded USB 2.0 v2
 - Balanced differential analog audio with phantom power, terminal block, and pre-amp audio
- Other options:
 - Redundant power, redundant link, SNMP

Product Overview

The modular design of the Orion XTender allows users to extend desktop control of remote computers. Servers can be located in secure areas, with workstations placed a distance away.

With support for single-head or dual-head video, as well as for USB keyboard and mouse, or touchscreens, this modular and feature-packed product family can be configured for a multitude of needs.

Common applications include control rooms, broadcast studios, outside broadcast vans, concert and theatre venues, AV distribution, medical imaging, and other industrial or military uses.

Connect them point-to-point or connect them to an Orion X or Orion FX switch and route video, audio, and USB control to the desired destination. Source and destination video formats can be different, for example, DVI input and HDMI output.

A wide range of chassis sizes, with provision for redundant power, makes the Orion XTender a versatile product. Use the larger sizes where multiple sources are in the same location and use the smaller units to create control sites near the users.

Connection status LEDs located on the front panel indicates the operating status of the unit. The chassis are all rack mountable and for most chassis, all connectors are on the same side of the chassis for convenience and ease of access.

Planning the installation To ensure the proper components are selected, first decide whether the application is for a point-to-point extension or a KVM switching system. For KVM switching, the Orion XTender units connect to the Orion digital KVM switch (see the Orion KVM switch datasheet). Next, determine the number of Transmitter (CPU) and Receiver (user) connection points required, and choose how to distribute these using the 2, 4, 6, or 21 card chassis. The density of the chassis types will impact decisions such as power, cabling access and rack space allocation.

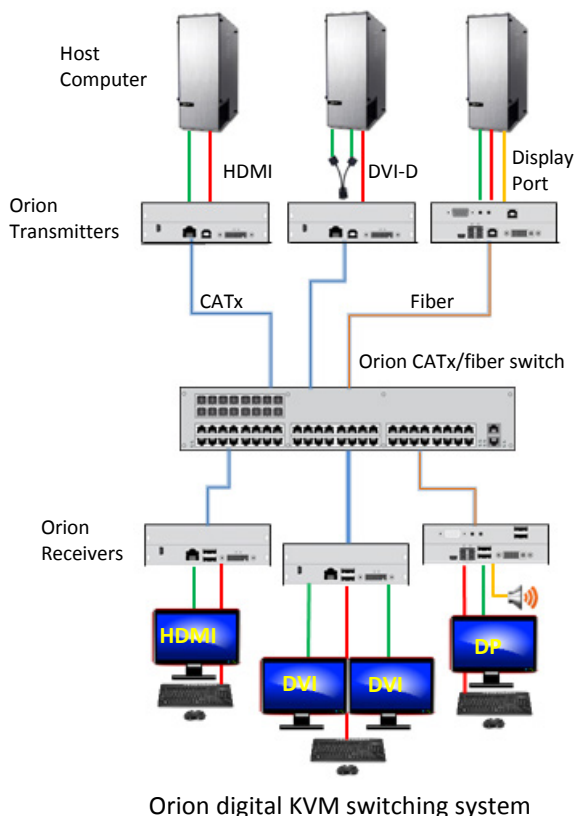
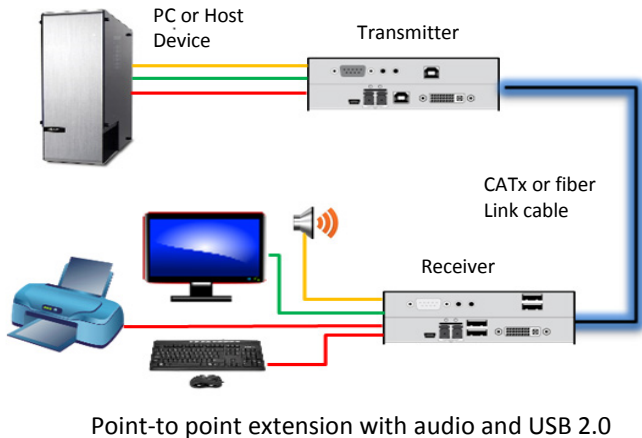

Main Cards and Option Cards All Orion XTender main cards have a link-port, either RJ45 for CATx or Duplex LC for fiber. Most main cards also have a video connector and a USB HID connector – 1× type B for the Transmitter and 2× type A for the Receiver. The Orion XTender option cards are installed on top of the main cards. The option cards are powered by the main card, and use the main card’s link cable. USB 2.0 High-Speed Cards are also available. Like the option cards, they are installed on top of the main cards, but have their own CATx or fiber link.

USB Option Cards The USB HID ports on the main cards support keyboard and mouse, bar-code scanners, touch screens, and similar types of devices. For additional USB support, add embedded USB option cards, which are available in two types:

- A USB HID card, with two type-A female USB HID device ports on the Receiver card.
- A USB 2.0 card with four type-A female USB 2.0 device ports on the Receiver card. These cards have transfer rates from 50 to 100Mbps. A USB powered hub can be added to expand the number of supported USB 2.0 devices.

Audio, Serial, and GPIO Option Cards A range of analog and digital audio cards are available for the Orion XTender. The analog audio option card supports bi-directional stereo audio transmission with a line-level interface. The digital audio option card supports digital audio using mini-XLR, coaxial, and optical interfaces. A symmetrical audio card is also available is for professional audio applications.

The RS-232 and RS-422 cards support full duplex transmission at rates up to 115,200 baud with hardware handshaking.

Other option cards include a GPIO card for up to eight configurable inputs/outputs, and a fan cartridge module for all Orion chassis types.

An SNMP card is available to monitor network traffic on the Orion XTender system. These can be installed on a 6-card chassis or a 21-card chassis.

Some option cards are available with several different interfaces on the same card, e.g. serial/audio/USB.

Display settings The default settings are normally satisfactory for most display connections. If needed, EDID information can be extracted from the displays, or loaded to the units from a binary file. Generally, no configuration is needed.

Link interface Main cards are available with either RJ-45 CATx connectors or LC fiber connectors. The LC connectors can be used with single mode or multimode fiber cables. Link speed can be either either 1G (1.25Gbs) or 3G (3.125Gbs). The higher speed link supports higher resolution and higher quality video. CATx cabling should be similar in quality to that used for Gigabit Ethernet installations, pinned to EIA/TIA 568-B. The use of solid core AWG24 shielded CAT5e or better is recommended. Fiber 3G requires single mode fiber cabling.

Redundant link transmission The redundant link option, with shared video, keyboard, mouse, audio and serial data, uses two CATx or fiber link cables that can be used in one of the following ways.

Use for mission critical installations The redundant link serves as a backup link should the primary link fail.

Share PC access with two remote users In this case, the Transmitter unit would be equipped with a redundant link, and the two Receivers would each be in a standard Orion Receiver chassis. Control of the PC is based on keyboard/mouse inactivity, which can be configured up to 10 seconds.

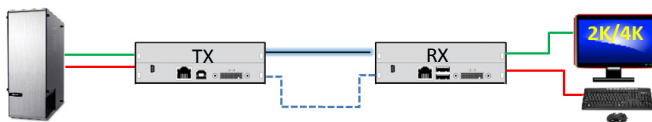

Redundant link

Redundant link used as a backup link

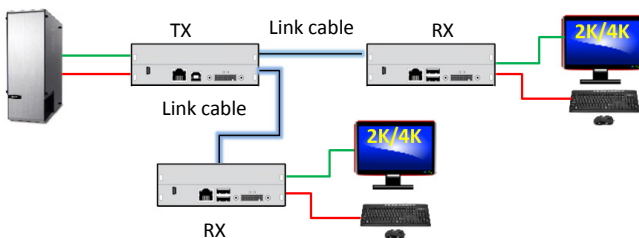

Two users sharing the resources of a common PC

One user can access two PCs The Orion XTender redundant link option allows a single user to access two computers without using a KVM switch. Switching between the two PCs is done using hotkeys on the keyboard connected to the Receiver.

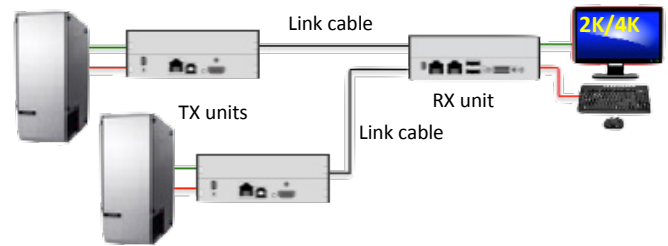

One user switching between two PCs

Fully redundant KVM switching system Orion XTenders with the redundant link option can be used with Orion KVM matrix switches to implement fully redundant switching. Interconnects can be CATx or fiber, and the video format can be a mix of DVI-D, VGA, HDMI, and DP. As in other applications, Add-on option cards are fully supported.

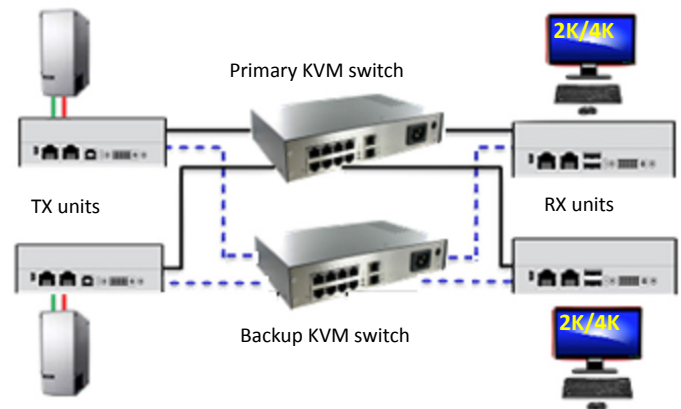

Implementation using a back-up KVM switch

Dual power supplies All Orion Xtender chassis include one power supply unit. Some chassis have an external power supply, while others have an internal power supply. All chassis types are available with dual power supplies when required. The redundant power supply should be specified as part of the original chassis order.

Video interface selection Orion XTenders can support industry standard VGA, DVI-D, HDMI, DP video signals. Dual-head DP main cards are also available.

DVI-I (VGA) video The Orion DVI-I Transmitter unit converts VGA input to a digital signal for transmission to the Receiver unit, which can have a DVI-D or HDMI display connected. A DVI-I dual-height Transmitter card is available which can generate an on-screen display with menu options to scale the VGA input to any DVI output up to 2048x1152@60Hz.

DVI-D video The standard DVI-D single link main card supports a maximum resolution of 1920x1200, together with USB connections for human interface devices, such as keyboard and mouse.



HDMI video There are 5 types of Orion XTender cards for HDMI video, each with HID USB support, and with either: CATx 1G or 3G; or fiber 1G or 3G interconnects.

- a) HDMI 1.3 HD
- b) HDMI 1.4 UHD
- c) HDMI 1.4 UHD Plus
- d) HDMI 2.0 UHD Plus
- e) HDMI 2.0 UHD with JPEG-XS

HDMI 1.3 HD This extender supports high definition HDMI video signals up to 1920x1200, including 3D formats and digital audio. The cards have locking HDMI connectors, and are compatible with standard Orion DVI-D and DP XTender cards. The embedded audio output is compatible with the companion digital audio option cards.

HDMI 1.4 UHD This extender supports ultra high definition HDMI video signals up to 4K30, including 3D formats and digital audio. The embedded audio output is compatible with the companion digital audio option cards.

HDMI 1.4 UHD Plus This extender adds a superior visually lossless video compression technique to the HDMI 1.4 UHD, for even higher fidelity video output.

HDMI 2.0 UHD Plus This extender supports HDMI 2.0 resolutions up to 4096x2160@60Hz, with 10 bit color depth (4:2:2), and 8 bit color depth (4:4:4). It uses the same advanced video compression codec used by the HDMI 1.4 HD Plus. It also supports HDCP copy protection.

HDMI 2.0 UHD with JPEG-XS This extender makes use of the JPEG XS video codec, enabling the extension of video signals at resolutions up to 5120x2150@50Hz using a 1G or 3G link. All digital audio standards are supported, as well as HDCP copy protection.

HDMI local video Each of the three types of HDMI extenders can be purchased with a local HDMI output at the Transmitter for connecting a local display. This feature is standard on the HDMI 2.0 UHD Plus extender.

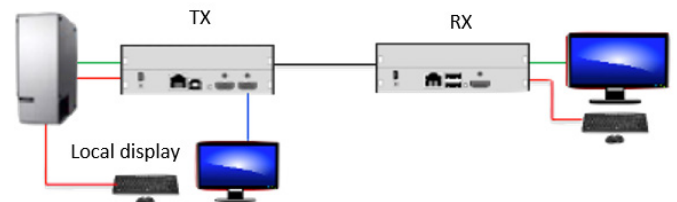

Orion HDMI KVM extension with local video

HDMI remote computer switching Each type of HDMI extender can also be purchased with a micro-HDMI input at the Receiver for connecting a source directly to the console. This allows for switching between a Transmitter input and a computer located at the Receiver.

This feature is standard on the HDMI 2.0 UHD Plus extender.

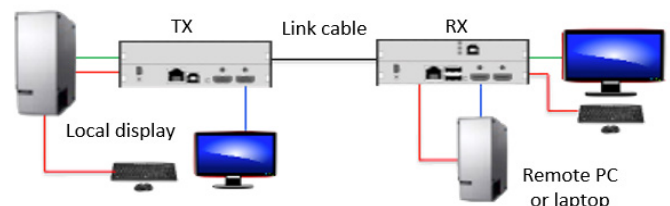

Orion HDMI KVM extension with remote PC connection

HDMI dual-head display The special HDMI half-card can be used to support HDMI dual-head video applications by providing a video path for the second HDMI video feed. This HDMI half-card has an HDMI connector and comes with a CATx or fiber link port.

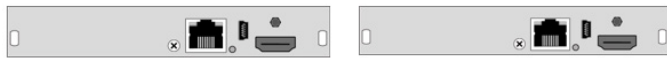

HDMI half-card for HDMI video only (CATx transmitter)

HDMI half-card for HDMI video only (CATx receiver)

(Note: this feature is not available with the HDMI 2.0 model)

DP video There are 5 different models of Orion DP extenders, all with regular USB-HID support, compatible with the Orion XT option cards and including many special features such as dual-head video input/output and support for DP embedded audio over a single CATx or fiber link cable.

- a) DP 1.1 (4K30, 1G CATx or 1G/3G fiber)
- b) DP 1.1 Plus (4K30, 1G CATx or 1G/3G fiber)
- c) DP 1.2 Plus (4K60, fiber 3G)
- d) DP 1.2 Plus Multi-Stream (2x1080p@60Hz)
- e) DP 1.2 with JPEG XS (5K/4K@60Hz)

DP 1.1 This model supports single-head video resolutions up to 4096x2160@30Hz. In addition to a primary full sized DP connector, it is equipped with a secondary mini DP connector for supporting dual-head resolutions up to 1920x1200@60Hz. USB HID keyboard and mouse support is standard.

DP 1.1 Plus This model adds a superior, visually lossless video compression technique to DP 1.1 features, for even higher fidelity video output. This allows synchronous dual-head video transmission up to 60fps with low latency.



DisplayPort 1.1 transmitter and receiver cards

DP 1.2 Plus This high-performance model enables perfect quality transmission of DP video up to 4K60 resolution with a 10-bit color depth, no frame drops, and 4:4:4 color sampling. PCM audio up to 96kHz can be transferred over the DP interface. Each card has a local mini-DP port, enabling the connection of a DP monitor at the PC end, and the connection of a PC at the remote user end.



DisplayPort 1.2 Plus fiber transmitter card

DisplayPort 1.2 Plus fiber receiver card

DP 1.2 Plus Multi-Stream The DP 1.2 Multi-Stream (MST) extender enables the operation of a server with DP MST graphics output from a remotely located dual screen workstation including two DP monitors, keyboard, and mouse over a single CATx or fiber connection. The dual monitors are connected together via an MST daisy chain link. The visually lossless video codec supports no frame drops and a full color depth (True Color) of 24-bit, 4:4:4.

DP 1.2 with JPEG XS This extender uses the JPEG XS video codec, to support resolutions up to 5120x2160@50Hz. It is available with CATx 1G link speed, as well as fiber 1G and 3G links. All standard digital audio formats are supported.

Mixed video interfaces Orion XTender cards in the same video/USB series are compatible with each other, to limit mismatches in mixed video installations. So, a VGA computer connected to a DVI-I Transmitter can be connected to an HDMI or DP Receiver. Mixing cards of a different series, such as mixing 1G and 3G series, is not possible.

Embedded audio

The HDMI and DP models support embedded audio, and can output audio to a display's built-in speakers. Output can also be through an analog audio or digital audio option card. Video types that don't support embedded audio, such as DVI or VGA, can use audio option cards as an input.

Chassis options A variety of chassis models are available for connecting 2, 4, 6, or 21 Orion XTender cards per chassis. Each chassis size can be supplied with redundant power or DC power. The 2, 6, and 21 card chassis also have internal IEC power options, and backplane options for sliding the Orion XTender cards in/out.

Specifications

Dimensions W × D × H

Chassis	inch	mm
2-card	5.7×5.8×1.7	145×147×44
2-card/IEC/DC	8.7×5.8×1.7	221×147×44
2-card/BPF/SNMP	8.7×5.8×1.7	221×147×44
4-card	11.6×5.8×1.7	296×147×44
6-card/1xIEC/DC	17.4×5.8×1.7	442×147×44
6-card/2xIEC	17.4×10.6×1.7	442×270×44
21-card	19.0×18.2×6.9	482×462×176

Estimated net weight (Varies by model)

Chassis	lb	kg
2-card	1.8	0.8
2-card redundant PSU	2.2	1.0
2-card/1xIEC/DC	3.1	1.4
2-card/BPF	3.8	1.7
2-card SNMP	4.0	1.8
4-card	3.3	1.5
4-card redundant PSU	3.8	1.7
6-card/1xIEC/DC	5.3	2.4
6-card/2xIEC/SNMP	9.5	4.3
21-card	22.7	10.3
21-card redundant PSU	25.7	11.6

Power

Chassis	Power Supply Voltage, AC and DC
2-card	5VDC, 3A
2-card/IEC/BPF/SNMP	100-240V, 50/60Hz, 0.7A / 5VDC, 5A
2-card DC-12	9.2V to 18V/12 VDC, 1.9A / 5VDC, 3A
2-card DC-24	18V to 36V/24VDC, 0.9A / 5VDC, 3A
2-card DC-48	36V to 72V/48VDC, 0.45A / 5VDC, 3A
4-card	5VDC, 5A
6-card/1xIEC	100-240V, 50/60Hz, 1.5A / 5VDC, 5A
6-card DC-12	9V to 18V/12 VDC, 4.5A / 5 VDC, 5A
6-card DC-24	18V to 36V/24VDC, 2.5A / 5VDC, 5A
6-card DC-48	36V to 72V/48VDC, 1.1A / 5VDC, 5A
6-card/IEC/BPF/SNMP	2 x 100-240V, 50/60Hz, 1.3A
21-card	1x 100-240V, 50/60Hz, 4A
21-card redundant	2x 100-240V, 50/60Hz, 4A

Link Bandwidth and Distance

Port type	Bandwidth
CATx 1G / Fiber 1G	1.25 Gbit/s (1000BASE-T)
CATx 3G / Fiber 3G	3.125 Gbit/s (2.5GBASE-T)
Port type	Distance
CATx 1G ^{1 2}	460 ft (140 m)
CATx 3G ^{1 2}	328 ft (100 m)
Fiber 1G SM module ³	SM OS1/OS2: 32,808 ft (10 km) MM OM3: 984 ft (300 m) Estimated
Fiber 1G MM module ⁴	MM OM1: 721 ft (220 m) MM OM3: 1,804 ft (550 m)
Fiber 3G SM module	SM OS1/OS2: 16,404 ft (5 km)

Notes:

- (1) CAT5e cabling is rated for 1000BASE-T and can also handle 2.5GBASE-T over shorter runs. Consider using CAT6 cable for longer runs.
- (2) When using AWG26/28 CATx stranded wire patch cables, the maximum extension distance is decreased by an estimated 50%.
- (3) Fiber 1G single-mode SFP module supplied is type LX 1310nm which supports both single-mode and multi-mode OM3 or higher. Increased multi-mode distance can be achieved with a mode conditioning cable. Test with multi-mode before installation.
- (4) Fiber 1G multi-mode SFP module supplied is type SX 850nm which supports legacy OM1 cable and longer distance with OM3 than single-mode SFP module. No mode conditioning cable is required.
- (5) There are further unspecified options for the fiber SFP modules such as long haul, bidirectional, or CWDM. Please contact the Rose sales department for more information.

LEDs

CATx/Fiber link status per port	Active connection and connection status for TX and RX
USB and video status per port	4-6 LED's including device ready, USB On, Video On, Video unknown for TX and RX
Chassis	Primary and Redundant Power Status LED

Video specifications

Resolution	
DP 1.2 JPEG XS DP 1.2 HDMI 2.0 JPEG XS	5120×1440 @60Hz 5120×2160 @50Hz 3840×2160 @60 Hz (10 bit, 4:4:4) 4096×2160 @60 Hz (10 bit, 4:4:4) 1920×1080 @240Hz
DP 1.2 Multi-Stream (MST)	2 × 1920×1200 @60Hz 2 × 4096×2160 @30Hz * 2 × 1920×1200 @120Hz * * Call Rose for availability
DP 1.1 dual-head	2 × 1920×1200 @60Hz
DP 1.1 single-head	3840×2160 @30Hz 4096×2160 @30Hz
HDMI 2.0	4096×2160 @60Hz (10 Bit, 4:2:2) 4096×2160 @60Hz (8 Bit, 4:4:4) 1920×1080 @240Hz
HDMI 1.4	3840×2160 @30Hz 4096×2160 @24Hz
HDMI 1.3 DVI/VGA	1920×1200 @60Hz 2048×1152 @60Hz
Notes: (1) Unless otherwise noted all resolutions are 8-bit 4:4:4. (2) Resolution is maximum at refresh rate or bit depth shown. (3) Lower resolutions complying with listed spec are supported.	
Bandwidth	
DP1.2 DP1.1 HDMI 2.0 HDMI 1.4 HDMI 1.3 DVI/VGA	17.28 Gbit/s (10-bit 4:4:4, HBR2) 6.37 Gbit/s 21.6 Gbit/s 14.4 Gbit/s 4.95 Gbit/s 4.95 Gbit/s

Environmental

Operating temperature	41°F ~ 113°F (5°C ~ 45°C)
Storage temperature	-13°F ~ 140°F (-25°C ~ 60°C)
Rel. humidity	Maximum 80% non-condensing
Sound pressure level	Maximum 43 dBA per fan

Approvals

Safety	IEC 62368-1, 3rd Edition
FCC	Part 15 Class A
CE EMC Directive	2014/30/EU
CE Low Voltage Directive	2014/35/EU
RoHS	2011/65/EU (RoHS 2 Recast)
WEEE	2012/19/EU
REACH	REACH 2.0

Audio specifications

Analog audio	
Format	16-bit 38.4KHz
Signal level	Line level, 5V Peak-Peak
Impedance	(In) 47 KΩ, (Out) 270 KΩ
Input/output	2 x 3.5 mm stereo jacks
Analog audio on USB 2.0	
Format	16-bit 8, 11.025, 16, 22.05, 32, 44.1, 48KHz
Signal level	Line level, 0.43V Peak-Peak
Input impedance	20 KΩ
Input/output	1× USB-B / 2× 3.5 mm stereo
Digital audio	
Compatibility	AES/EBU, S/PDIF, EIAJ CP1201, IEC 60958
Standards	Stereo LPCM, Dolby digital, DTS, DTS-HD (5.1), Dolby digital plus
Bit depth	24-bit
Sample rate	32 to 192 kHz
Transmitter In	1× Mini XLR
Receiver Out	1× Coaxial S/PDIF, RCA, Cinch, 1× Optical S/PDIF, TOSLINK
Balanced Audio	
Bit depth	24-bit
Sample rate	32 to 192 kHz, default = 48 kHz
Input signal	Maximum 6.4 dBu balanced, Maximum 0.4 dBu unbalanced
Gain	0 dB
Output signal	8.1 dBu balanced, 2.1 dBu unbalanced
Phantom power	48 VDC
Pre-amp	10 to 65 dB
Transmitter In	1× 6-pin Phoenix terminal block
Receiver Out	1× 6-pin Phoenix terminal block

USB, RS-232, and RS-422

USB-HID current	100ma/port (included on all main cards)
USB 2.0 current	500ma/port
USB 2.0 embedded speed	50 to 100 Mbps
RS-232 format	Full duplex H/W handshake, DTE
RS-232 speed	Standard - Up to 19,200 baud, High performance - Up to 115,200 baud
RS-422 format	Differential full-duplex No H/W handshake
RS-422 speed	Up to 115,200 baud

Main card connectors

Card type	Transmitter	Receiver
DVI-D single-link	1× DVI-D female 1× USB Type-B 1× or 2× RJ45 or LC duplex fiber	1× DVI-D female 2× USB Type-A 1× or 2× RJ45 or LC duplex fiber
DVI-I VGA (VGA no scaling)	1× DVI-I female 1× USB Type-B 1× or 2× RJ45 or LC duplex fiber	1× DVI-I female 2× USB Type-A 1× or 2× RJ45 or LC duplex fiber
DVI-I VGA (VGA with full scaling, dual-height card)	1× DVI-I female 1× USB Type-B 1× IR remote ctrl 1× RJ45 or LC duplex fiber	Not available
HDMI	1× HDMI female 1× USB Type-B 1× or 2× RJ45 or LC duplex fiber	1× HDMI female 2× USB Type-A 1× or 2× RJ45 or LC duplex fiber
HDMI with local video out	2× HDMI female 1× USB Type-B 1× or 2× RJ45 or LC duplex fiber	Not available
HDMI with remote switch function	Not available	2× HDMI female 2× USB Type-A 1× or 2× RJ45 or LC duplex fiber
HDMI video only	1× HDMI female 1× RJ45 or LC duplex fiber	1× HDMI female 1× RJ45 or LC duplex fiber
DP 1.1	1× DP female 1× Mini DP female 1× USB Type-B 1× or 2× RJ45 or LC duplex fiber	1× DP female 1× Mini DP female 2× USB Type-A 1× or 2× RJ45 or LC duplex fiber
DP 1.2	1× DP female 1× Mini DP female 1× USB Type-B 1× or 2× RJ45 or LC duplex fiber	1× DP female 1× Mini DP female 2× USB Type-A 1× or 2× RJ45 or LC duplex fiber
DP 1.2 with JPEG XS	1× DP female 1× USB Type-B 1× or 2× RJ45 or LC duplex fiber	1× DP female 2× USB Type-A 1× or 2× RJ45 or LC duplex fiber
DP 1.2 with JPEG XS local video and remote PC	1× DP female 1× Mini DP female 1× USB Type-B 1× or 2× RJ45 or LC duplex fiber	1× DP female 1× Mini DP female 2× USB Type-A 1× or 2× RJ45 or LC duplex fiber

* All cards above include 1x micro-USB jack as a service port

Option card connectors

Card type	Transmitter	Receiver
USB-HID	1× USB Type-B	2× USB Type-A
Embedded USB 2.0	1× USB Type-B	4× USB Type-A
Audio + Serial (RS232 or RS422)	2× 3.5 mm audio jack 1× DB9 female serial	2× 3.5 mm audio jack 1× DB9 female serial
Audio + RS232 and PS/2	2× 3.5 mm audio jack 1× DB9 serial (F) 2× PS2 mini-din6F	2× 3.5 mm audio jack 1× DB9 serial (M) 2× PS2 mini-din6F
Audio + Serial (RS232 or RS422) and USB-HID	2× 3.5 mm audio jack 1× DB9 female serial 1× USB Type-B	2× 3.5 mm audio jack 1× DB9 female serial 2× USB Type-A
Audio + Serial (RS232 or RS422) Embedded USB 2.0	2× 3.5 mm audio jack 1× DB9 female serial 1× USB Type-B	2× 3.5 mm audio jack 1× DB9 female serial 4× USB Type-A
2× Audio + serial (RS422)	4× 3.5 mm audio jack 2× DB9 female serial	4× 3.5 mm audio jack 2× DB9 male serial
Digital audio	1× S/PDIF-RCA 1× AES/EBU-Mini XLR 1× S/PDIF-TOSLINK	1× S/PDIF-RCA 1× AES/EBU-Mini-XLR 1× S/PDIF-TOSLINK
Balanced analog audio	1× phantom power switch 1× 6-pin Phoenix terminal block 1× DIP pre-amp	1× 6-pin Phoenix terminal block 1× DIP pre-amp
Balanced analog audio with embedded USB 2.0, up to 50/100Mbps	1× phantom power switch 1× 6-pin Phoenix terminal block 1× DIP pre-amp 1× USB Type-B	1× 6-pin Phoenix terminal block 1× DIP pre-amp 4× USB Type-A
GPIO	Not available	1× DB9 male for dry contact
GPIO Analog audio RS232 serial	Not available	1× DB9 male for dry contact 2× 3.5 mm audio jack 1× DB9 serial (F)
USB 2.0 high speed with a dedicated link cable port	1× USB Type-B 1× USB mini (service) 1× RJ45 or LC type duplex fiber	4× USB Type-A 1× USB mini (service) 1× RJ45 or LC type duplex fiber
FAN module	Can be installed in any chassis slot	
SNMP module	1× Ethernet RJ45 Installs in slot #5 of 6-card BPF chassis or slot #21 of a 21-card chassis	

Part numbers

The Orion XTender is a highly configurable product and has many variations. The part numbering system is described below.

Product part numbers consist of a chassis and power options with one or more main Transmitter or Receiver cards installed into the chassis with zero or more option cards.

The variations of the main card as listed in Tables 1 and Table 2 and shown in Table 6 on page 17 consist of:

- Transmitter or Receiver
- Presence or absence of redundant link
- Link and speed: either CATx 1G, CATx 3G, Fiber 1G, or Fiber 3G; 1G and 3G are not cross-compatible
- Type of video: DVI-D, DVI-I, HDMI, or DP
- Regular or high-performance video; these are not-compatible with one another

To identify the part number, six things must be specified:

1. The main card part number from Table 1
2. The number of main cards (b)
3. The option card part number from Table 2
4. The number of option cards (c)
5. The chassis size (a) from table 3
6. The power options (p) from Table 3

The part number is then formed:

Chassis	—	Main card	/	Option card	/	Power option
Part number from Tables 1 and 2				Part number from Table 3 c = Number of option cards		Power option (p) from Table 5
a = Chassis size from Table 4						
b = Number of main cards						

Stacking part numbers

When different styles of main cards or option cards are desired then just append the second type to the first type separated by /.

Orion XTender: 21-Card Rack Chassis

The Orion XTender 21-card chassis is 4U high. When installed in a computer rack, it saves considerable rack space compared to the individual Orion 2/4/6 card chassis and it significantly reduces the power consumption for an equivalent number of stand-alone Transmitter or Receiver chassis.

Several combinations of Orion XTender main card and option cards can be installed in the chassis, up to a maximum of 21 cards. Each Orion option card needs to be installed adjacent to an Orion main card. Blanking plates are available for covering unused chassis slots, see Table 4.

Table 1. Transmitter part number with main card installed into chassis (a) and number of main cards (b)

Card type	HP ¹	Transmitter			
		CATx 1G	CATx 3G	Fiber 1G	Fiber 3G
DVI-D		OTa-SLDTXUDbD		OTa-SLDFSUDbD	
DVI-I (VGA)		OTa-SLDTXUSbV		OTa-SLDFSUSbV	
DVI-I (VGA) scaling ²		OTa-SLDTXUDbV		OTa-SLDFSUDbV	OTa-SLDF3UDbV
DP 1.1 dual video		OTa-SLDTXUDKb		OTa-SLDFSUDKb	OTa-SLDF3UDKb
DP 1.1 Plus dual video	✓	OTa-SLDTXUDU b		OTa-SLDFSUDU b	OTa-SLDF3UDU b
DP 1.2 Plus	✓				OTa-SLDF3UDX b
DP 1.2 Plus local video out	✓		OTa-DLDT3UDX b		OTa-DLDF3UDX b
DP 1.2 Plus local video out, Multi-Stream	✓		OTa-DLDT3DUM b		OTa-DLDF3UDM b
DP 1.2 JPEG-XS		OTa-SLDTXUDS b		OTa-SLDFSUDS b	OTa-SLDF3UDS b
DP 1.2 JPEG-XS local video out		OTa-DLDTXUDS bW		OTa-DLDFSUDS bW	OTa-DLDF3UDS bW
HDMI 1.3		OTa-SLDTXUH bH		OTa-SLDFSUH bH	
HDMI 1.3 video only ³		OTa-SLDTX0H bH		OTa-SLDFS0H bH	
HDMI 1.3 local video out		OTa-DLDTXUH bH		OTa-DLDFSUH bH	
HDMI 1.4 local video out		OTa-DLDTXUHL bH		OTa-DLDFSUHL bH	OTa-DLDF3UHL bH
HDMI 1.4 Plus local video out	✓	OTa-DLDTXUH bH		OTa-DLDFSUH bH	OTa-DLDF3UH bH
HDMI 2.0 Plus local video out, HDCP	✓		OTa-DLDT3UH Xb		OTa-DLDF3UH Xb
HDMI 2.0 Plus, JPEG-XS, local video out, HDCP	✓	OTa-DLDTXUHS bWH		OTa-DLDFSUHS bWH	OTa-DLDF3UHS bWH
Card type	HP ¹	Transmitter with redundant link			
		CATx	CATx 3G	Fiber 1G	Fiber 3G
DVI-D		OTa-SLD2CUD bD		OTa-SLD2SUD bD	
DVI-I (VGA)		OTa-SLD2CUS bV		OTa-SLD2SUS bV	OTa-SLDFRUS bV
DVI-I (VGA) scaling ²		Not available with a redundant link port			
DP 1.1 dual video		OTa-SLD2CUDK b		OTa-SLD2SUDK b	OTa-SLDFRUDK b
DP 1.1 Plus dual video	✓	OTa-SLD2CUDU b		OTa-SLD2SUDU b	OTa-SLDFRUDU b
DP 1.2 Plus	✓				OTa-SLDFRUDX b
DP 1.2 Plus local video out	✓		OTa-DLDTRUDX b		OTa-DLDFRUDX b
DP 1.2 Plus local video out, Multi-Stream	✓		OTa-DLDTRUDM ib		OTa-DLDFRUDM ib
DP 1.2 JPEG-XS		OTa-SLD2CUDS1 b		OTa-SLD2SUDS b	OTa-SLDFRUDS b
DP 1.2 JPEG-XS local video out		OTa-DLD2CUDS bW		OTa-DLD2SUDS bW	OTa-DLDFRUDS bW
HDMI 1.3		OTa-SLD2CUH bH		OTa-SLD2SUH bH	
HDMI 1.3 local video		OTa-DLD2CUH bH		OTa-DLD2SUH bH	
HDMI 1.4 local video out		OTa-DLD2CUHL b		OTa-DLD2SUHL1	OTa-DLDFRUHL1
HDMI 1.4 Plus local video out	✓	OTa-DLD2CUHU b		OTa-DLD2SUHU b	OTa-DLDFRUHU b
HDMI 2.0 Plus local video out, HDCP	✓		OTa-DLDTRUH Xb		OTa-DLDFRUH Xb
HDMI 2.0 Plus, JPEG-XS, local video out, HDCP	✓	OTa-DLD2CUHS bW		OTa-DLD2SUHS bW	OTa-DLDFRUHS bW

¹ High performance video, typically lossless video, display without delay or frame drops in the highest resolutions

² Full height DVI-I(VGA) card cannot support any option cards

³ HDMI video only card does not support option cards

Table 2. Receiver part number with main card installed into chassis (a) and number of main cards (b)

Card type	HP ¹	Receiver			
		CATx 1G	CATx 3G	Fiber 1G	Fiber 3G
DVI-D		ORa-SRDTXUDbD		ORa-SRDFSUDbD	
DVI-I (VGA)		ORa-SRDTXUSbV		ORa-SRDFSUSbV	
DVI-I (VGA) scaling ²		DVI-I, DbV is not available as a Receiver unit, use SbV			
DP 1.1 dual video		ORa-SRDTXUDKb		ORa-SRDFSUDKb	ORa-SRDF3UDKb
DP 1.1 Plus dual video	✓	ORa-SRDTXUDUb		ORa-SRDFSUDUb	ORa-SRDF3UDUb
DP 1.2 Plus	✓				ORa-SRDF3UDXb
DP 1.2 Plus remote PC in	✓		ORa-DRDT3UDXb		ORa-DRDF3UDXb
DP 1.2 Plus remote PC in, Multi-Stream	✓		ORa-DRDT3UDMb		ORa-DRDF3UDMb
DP 1.2 JPEG-XS		ORa-SRDTXUDSb		ORa-SRDFSUDSb	ORa-SRDF3UDSb
DP 1.2 JPEG-XS remote PC in		ORa-DRDTXUDS1bW		ORa-DRDFSUDSbW	ORa-DRDF3UDSbW
HDMI 1.3		ORa-SRDTXUHbH		ORa-SRDFSUHbH	
HDMI 1.3 video only ³		ORa-SRDTXOHbH		ORa-SRDFS0HbH	
HDMI 1.3 remote PC ⁴		ORa-DRDTXUHbHW		ORa-DRDFSUHbHW	ORa-DRDF3UHLb
HDMI 1.4 remote PC		ORa-DRDTXUHLbW		ORa-DRDFSUHLbW	ORa-DRDF3UHLbW
HDMI 1.4 Plus remote PC in	✓	ORa-DRDTXUHUb		ORa-DRDFSUHUb	ORa-DRDF3UHUb
HDMI 2.0 Plus remote PC in, HDCP	✓		ORa-DRDT3UHXb		ORa-DRDF3UHXb
HDMI 2.0 Plus, JPEG-XS, local video out, HDCP		ORa-DRDTXUHSbW		ORa-DRDFSUHSbW	ORa-DLDF3UHSbW
Card type	HP ¹	Receiver with redundant link			
		CATx	CATx 3G	Fiber 1G	Fiber 3G
DVI-D		ORa-SRD2CUDbD		ORa-SRD2SUDbD	
DVI-I (VGA)		ORa-SRD2CUSbV		ORa-SRD2SUSbV	
DVI-I (VGA) scaling ²		Not available with a redundant link port			
DP 1.1 dual video		ORa-SRD2CUDKb		ORa-SRD2SUDKb	ORa-SRDFRUDKb
DP 1.1 Plus dual video	✓	ORa-SRD2CUDUb		ORa-SRD2SUDUb	ORa-SRDFRUDUb
DP 1.2 Plus	✓				ORa-SRDFRUDXb
DP 1.2 Plus remote PC in	✓		ORa-DRDTRUDXb		ORa-DRDFRUDXb
DP 1.2 Plus remote PC in, Multi-Stream	✓		ORa-DRDTRUDMb		ORa-DRDFRUDMb
DP 1.2 JPEG-XS	✓	ORa-SRD2CUDSb		ORa SRD2SUDSb	ORa-SRDFRUDSb
DP 1.2 JPEG-XS remote PC in	✓	ORa-DRD2CUDSbW		ORa DRD2SUDSbW	ORa-DRDFRUDSbW
HDMI 1.3		ORa-SRD2CUHbH		ORa-SRD2SUHbH	
HDMI 1.3 remote PC ⁴		ORa-DRD2CUHbHW		ORa-DRD2SUHbHW	
HDMI 1.4 remote PC in		ORa-DRD2CUHLbW		ORa-DRD2SUHLbW	ORa-DRDFRUHLbW
HDMI 1.4 Plus remote PC in	✓	ORa-DRD2CUHUb		ORa-DRD2SUHUb	ORa- DRDFRUHUb
HDMI 2.0 Plus remote PC in, HDCP	✓		ORa-DRDTRUHXb		ORa-DRDFRUHXb
HDMI 2.0 Plus, JPEG-XS, local video out, HDCP	✓	ORa-DRD2CUHSbW		ORa-DRD2SUHSbW	ORa-DRDFRUHSbW

¹ High performance video, typically lossless video, display without delay or frame drops in the highest resolutions
² Full height DVI-I(VGA) card cannot support any option cards
³ HDMI video only card does not support option cards
⁴ This function requires a top card with USB to support USB-HID or USB 2.0

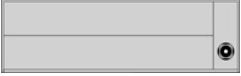
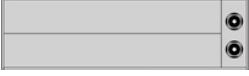

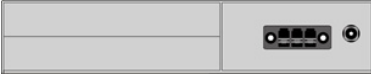



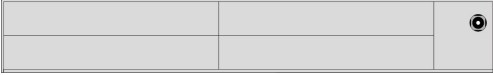

Table 3. Part number of option card when installed into chassis with number of option cards (c)

Part number	Description
cH	USB-HID
cF	Embedded USB 2.0 with 4x device ports up to 100 Mbps
cAS	Analog Audio + RS232
cAS/115	Analog Audio + RS232 up to 115.2K baud
cA422	Analog Audio + RS422
cAS+cPS	Analog Audio + RS232 + PS/2
cAS+cH	Analog Audio + RS232 + USB-HID
cA4+cH	Analog Audio + RS422 + USB-HID
cAS+cF	Analog Audio + RS232 + embedded USB 2.0 with 4x device ports up to 100 Mbps
cASF/115	Analog Audio + RS232 up to 115.2K baud + embedded USB 2.0 with 4x device ports up to 100 Mbps
cA4+cF	Analog Audio + RS422 + embedded USB 2.0 with 4x device ports up to 100 Mbps
c2A422	Dual Analog Audio + Dual RS422
cDA+cF	Digital Audio, S/P-DIF, Mini-XLR, TOS-L + embedded USB 2.0 with 4x device ports up to 100 Mbps
cAB	Balanced symmetrical analog audio with phantom power, terminal block and pre-amp
cAB+cF	Balanced symmetrical analog audio (as above) + embedded USB 2.0 with 4x device ports up to 100 Mbps
cPB	Push button for displaying OSD on Receiver unit for user with no keyboard
cGPIO	GPIO, with 8 configurable GPIO In/Out
cGPIO+cAS	GPIO, with 8 configurable GPIO In/Out + analog audio + RS232
cSNMP	Monitoring module with SNMP, Ethernet, and RS232 for CH07 and CH21 chassis only

Table 4. Mounting brackets and accessories

Part number	Description
RM-OEE-02/19	19" rackmount kit for chassis size 2
RM-OEE-03/19	19" rackmount kit for chassis size 3
RM-OEE-04/19	19" rackmount kit for chassis size 4
RM-OEE-06/19	19" rackmount kit for chassis size 6 and 7
RM-OEE-TRAY/19	Rackmount Tray, 1U 19", for 2, 4, or 6 card chassis
RM-UDDR-1U	Under desk mounting brackets, for 2, 4, or 6 card chassis. "L" shaped bracket fits either side of the Orion chassis
RM-UDDR-1U/K1	Under desk mounting brackets, for 2, 4, or 6 card chassis. "L" shaped bracket fits either side of the Orion chassis, includes 1 set of green color DIN-Rail mounting clips
OEE-CP01	1 slot blanking plate for the 2, 4, or 6 card chassis
OEE-CP01/CH21	1 slot blanking plate for 21-card chassis
OEE-CP02/CH21	2 slot blanking plate for 21-card chassis
OEE-CP04/CH21	4 slot blanking plate for 21-card chassis
FAN-OEE-CH07	Optional fan for chassis size 7, may be required, contact Rose

Table 5. Chassis options

Chassis size (a)	Part number Chassis	Power option (p)	Chassis description
2	OEE-CH02	1	Standard +5V power supply 
2	OEE-CH02/RP OEE-CH02/DP	/RP ¹ /DP ²	Standard + Redundant +5V power supplies 
3	OEE/CH03 OEE-CH03/DP	1 /DP ²	Standard IEC power and +5V redundant power supply 
3	OEE-CH03/D12 OEE-CH03/D24 OEE-CH03/D48	/D12 ¹ /D24 ¹ /D48 ¹	DC input (12V, 24V, or 48V) and +5V redundant power supply 
5	OEE-CH05/BPF OEE-CH05/BPF/DP	1 /DP ²	Standard IEC power and +5V redundant power, backplane 
5	OEE-CH05/BPF/S	/BPF/S ²	Standard IEC power and +5V redundant power, backplane, hot swappable 
5	OEE-CH05/BPF/SNMP	/BPF/SNMP ²	Standard IEC power and +5V redundant power, backplane and IP management (SNMP) 
4	OEE-CH04	1	Standard +5V power supply 
4	OEE-CH04/RP OEE-CH04/DP	/RP ¹ /DP ²	Redundant +5V power supplies 

¹ Ships with one external power supply
² Ships with two external power supplies

Table 5. Continued

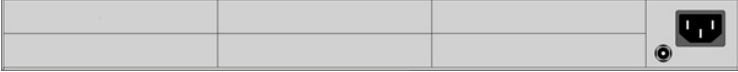
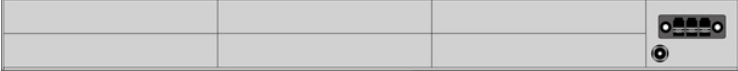
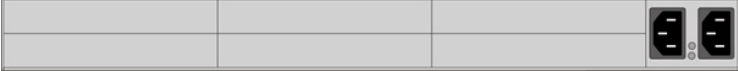
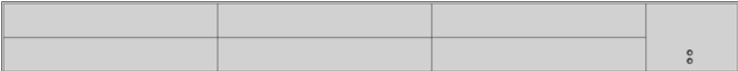
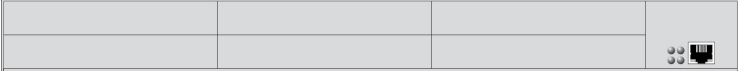
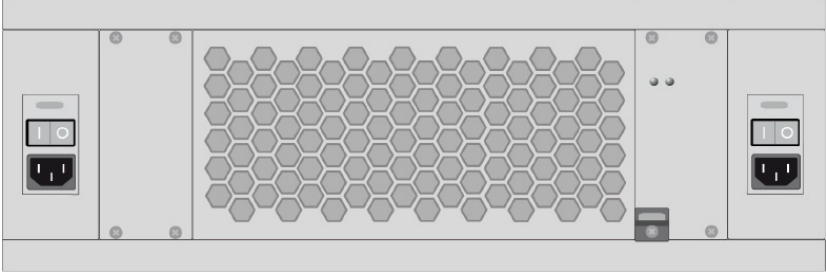
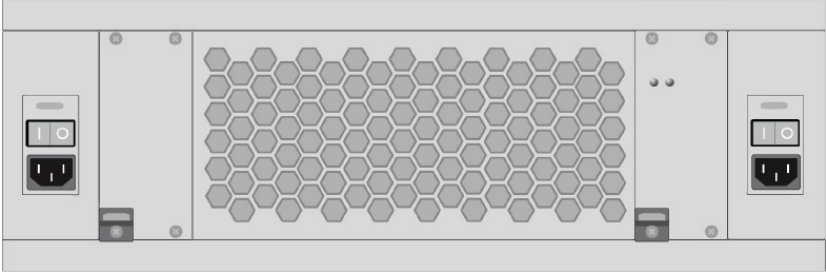
Chassis size (a)	Part number Chassis	Power option (p)	Chassis description
6	OEE-CH06/R1/RP OEE-CH06/DP	/RP ¹ /DP ²	Standard IEC power and +5V redundant power 
6	OEE-CH06/D12 OEE-CH06/D24 OEE-CH06/D48	/D12 ¹ /D24 ¹ /D48 ¹	DC input (12V, 24V, or 48V) and +5V redundant power supply 
7	OEE-CH07/BPF/DP OEE-CH07/BPF/DP/SFN	/BPF/DP ²	Backplane with redundant IEC power, hot swappable, front mount, /SFN option provides a silent fan 
7	OEE-CH07/BPB/DP OEE-CH07/BPB/DP/SFN	/BPB/DP ²	Backplane with redundant IEC power, hot swappable, rear access to power, /SFN option provides a silent fan 
8	OEE-CH08/BPB/DP/SNMP	/BPB/DP /SNMP ²	Backplane with redundant IEC power, hot swappable, rear access to power and IP management (SNMP) 
21	OEE-CH21/RP	/RP ¹	2x internal swappable IEC, backplane 
21	OEE-CH21/DP	/DP ²	2x internal swappable IEC, redundant PSU's, backplane 

¹ Ships with one installed power supply

² Ships with two installed power supplies

Table 6. Part numbers for main card when specified without a chassis

TRANSMITTER	RECEIVER	Figure	Local Video	2nd Link	Description
DVI-D XTenders					
OEC-SLDTXUD1D/IRK	OEC-SRDTXUD1D/IRK	A			DVI-D single link, USB-HID, CATx 1G, 1920×1200
OEC-SLDFSUD1D/IRK	OEC-SRDFSUD1D/IRK	A			DVI-D single link, USB-HID, Fiber 1G, 1920×1200
OEC-SLD2CUD1D/IRK	OEC-SRD2CUD1D/IRK	B		✓	DVI-D single link, USB-HID, redundant CATx 1G, 1920×1200
OEC-SLD2SUD1D/IRK	OEC-SRD2SUD1D/IRK	B		✓	DVI-D single link, USB-HID, redundant Fiber 1G, 1920×1200
DVI-I (VGA) XTenders					
OEC-SLDTXUS1V/IRK	OEC-SRDTXUS1V/IRK	C			DVI-I/VGA, USB-HID, CATx 1G, 1920×1200
OEC-SLDFSUS1V/IRK	OEC-SRDFSUS1V/IRK	C			DVI-I/VGA, USB-HID, Fiber 1G, 1920×1200
OEC-SLD2CUS1V/IRK	OEC-SRD2CUS1V/IRK	D		✓	DVI-I/VGA, USB-HID, redundant CATx 1G, 1920×1200
OEC-SLD2SUS1V/IRK	OEC-SRD2SUS1V/IRK	D		✓	DVI-I/VGA, USB-HID, redundant Fiber 1G, 1920×1200
OEC-SLDTXUD1V/IRK		E			DVI-I/VGA Scaling, USB-HID, Dual Height, CATx 1G, 1920×1200
OEC-SLDFSUD1V/IRK		E			DVI-I/VGA Scaling, USB-HID, Dual Height, Fiber 1G, 1920×1200
OEC-SLDF3UD1V/IRK		E			DVI-I/VGA Scaling, USB-HID, Dual Height, Fiber 3G, 1920×1200
HDMI 1.3 XTenders (Video only)					
OEC-SLDTX0H1H/IRK	OEC-SRDTX0H1H/IRK	J			HDMI 1.3 Video only, CATx 1G, 1920×1200
OEC-SLDFS0H1H/IRK	OEC-SRDFS0H1H/IRK	J			HDMI 1.3 Video only, Fiber 1G, 1920×1200
HDMI 1.3 XTenders					
OEC-SLDTXUH1H/IRK	OEC-SRDTXUH1H/IRK	K			HDMI 1.3, USB-HID, CATx 1G, 1920×1200
OEC-SLDFSUH1H/IRK	OEC-SRDFSUH1H/IRK	K			HDMI 1.3, USB-HID, Fiber 1G, 1920×1200
OEC-SLD2CUH1H/IRK	OEC-SRD2CUH1H/IRK	L		✓	HDMI 1.3, USB-HID, redundant CATx 1G, 1920×1200
OEC-SLD2SUH1H/IRK	OEC-SRD2SUH1H/IRK	L		✓	HDMI 1.3, USB-HID, redundant Fiber 1G, 1920×1200
HDMI 1.3 XTenders with Local video/PC					
OEC-DLDTXUH1H/IRK		M	✓		HDMI 1.3 Local video out, USB-HID, CATx 1G, 1920×1200
OEC-DLDFSUH1H/IRK		M	✓		HDMI 1.3 Local video out, USB-HID, Fiber 1G, 1920×1200
OEC-DLD2CUH1H/IRK		N	✓	✓	HDMI 1.3 Local video out, USB-HID, redundant CATx 1G, 1920×1200
OEC-DLD2SUH1H/IRK		N	✓	✓	HDMI 1.3 Local video out, USB-HID, redundant Fiber 1G, 1920×1200
	OEC-DRDTXUH1HW/IRK	O	✓		HDMI 1.3 with local PC, USB-HID, CATx 1G, 1920×1200
	OEC-DRDFSUH1HW/IRK	O	✓		HDMI 1.3 with local PC, USB-HID, Fiber 1G, 1920×1200
	OEC-DRD2CUH1HW/IRK	P	✓	✓	HDMI 1.3 with local PC, USB-HID, redundant CATx 1G, 1920×1200
	OEC-DRD2SUH1HW/IRK	P	✓	✓	HDMI 1.3 with local PC, USB-HID, redundant Fiber 1G, 1920×1200
HDMI 1.4 UHD Xtenders with Local video/PC					
OEC-DLDTXUHL1/IRK	OEC-DRDTXUHL1W/IRK	Q	✓		HDMI 1.4, USB-HID, CATx 1G, 4K/30, local video and PC
OEC-DLDFSUHL1/IRK	OEC-DRDFSUHL1W/IRK	Q	✓		HDMI 1.4, USB-HID, Fiber 1G, 4K/30, local video and PC
OEC-DLDF3UHL1/IRK	OEC-DRDF3UHL1W/IRK	Q	✓		HDMI 1.4, USB-HID, Fiber 3G, 4K/30, local video and PC
OEC-DLD2CUHL1/IRK	OEC-DRD2CUHL1W/IRK	R	✓	✓	HDMI 1.4, USB-HID, redundant CATx 1G, 4K/30, local video and PC
OEC-DLD2SUHL1/IRK	OEC-DRD2SUHL1W/IRK	R	✓	✓	HDMI 1.4, USB-HID, redundant Fiber 1G, 4K/30, local video and PC
OEC-DLDFRUHL1/IRK	OEC-DRDFRUHL1W/IRK	R	✓	✓	HDMI 1.4, USB-HID, redundant Fiber 3G, 4K/30, local video and PC
HDMI 1.4 UHD Plus Xtenders with Local video/PC					
OEC-DLDTXUHU1/IRK	OEC-DRDTXUHU1/IRK	Q	✓		HDMI 1.4 Plus, USB-HID, CATx 1G, 4K/30, local video and PC
OEC-DLDFSUHU1/IRK	OEC-DRDFSUHU1/IRK	Q	✓		HDMI 1.4 Plus, USB-HID, Fiber 1G, 4K/30, local video and PC
OEC-DLDF3UHU1/IRK	OEC-DRDF3UHU1/IRK	Q	✓		HDMI 1.4 Plus, USB-HID, Fiber 3G, 4K/30, local video and PC
OEC-DLD2CUHU1/IRK	OEC-DRD2CUHU1/IRK	R	✓	✓	HDMI 1.4 Plus, USB-HID, redundant CATx 1G, 4K/30, local video/PC
OEC-DLD2SUHU1/IRK	OEC-DRD2SUHU1/IRK	R	✓	✓	HDMI 1.4 Plus, USB-HID, redundant Fiber 1G, 4K/30, local video/PC
OEC-DLDFRUHU1/IRK	OEC-DRDFRUHU1/IRK	R	✓	✓	HDMI 1.4 Plus, USB-HID, redundant Fiber 3G, 4K/30, local video/PC
HDMI 2.0 UHD Plus XTenders with Local video/PC, HDCP					
OEC-DLDT3UHX1/IRK	OEC-DRDT3UHX1/IRK	Q	✓		HDMI 2.0 Plus, USB-HID, CATx 3G, 4K/60, local video/PC, HDCP
OEC-DLDF3UHX1/IRK	OEC-DRDF3UHX1/IRK	Q	✓		HDMI 2.0 Plus, USB-HID, Fiber 3G, 4K/60, local video/PC, HDCP
OEC-DLDT3UHX1/IRK	OEC-DRDT3UHX1/IRK	R	✓	✓	HDMI 2.0 Plus, USB-HID, redundant CATx 3G, 4K/60, local video/PC, HDCP
OEC-DLDF3UHX1/IRK	OEC-DRDF3UHX1/IRK	R	✓	✓	HDMI 2.0 Plus, USB-HID, redundant Fiber 3G, 4K/60, local video/PC, HDCP

Table 6. Part numbers for main card when specified without a chassis, Continued

TRANSMITTER	RECEIVER	Figure	Local Video	Dual Head	2nd Link	Description
HDMI 2.0 Xtenders with JPEG-XS codec, local video out/PC in, HDCP						
OEC-DLDTXUHS1W/IRK	OEC-DRDTXUHS1W/IRK	Q	✓			HDMI 2.0, USB-HID, CATx 1G, 4K/5K@60, local video/PC, HDCP
OEC-DLDFSUHS1W/IRK	OEC-DRDFSUHS1W/IRK	Q	✓			HDMI 2.0, USB-HID, Fiber 1G, 4K/5K@60, local video/PC, HDCP
OEC-DLDF3UHS1W/IRK	OEC-DRDF3UHS1W/IRK	Q	✓			HDMI 2.0, USB-HID, Fiber 3G , 4K/5K@60, local video/PC, HDCP
OEC-DLD2CUHS1W/IRK	OEC-DRD2CUHS1W/IRK	R	✓		✓	HDMI 2.0, USB-HID, red. CATx 1G, 4K/5K@60, local video/PC, HDCP
OEC-DLD2SUHS1W/IRK	OEC-DRD2SUHS1W/IRK	R	✓		✓	HDMI 2.0, USB-HID, red. Fiber 1G, 4K/5K@60, local video/PC, HDCP
OEC-DLDFRUHS1W/IRK	OEC-DRDFRUHS1W/IRK	R	✓		✓	HDMI 2.0, USB-HID, red. Fiber 3G , 4K/5K@60, local video/PC, HDCP
DP 1.1 Xtenders with dual video input, dual output						
OEC-SLDTXUDK1/IRK	OEC-SRDTXUDK1/IRK	S		✓		DP 1.1, USB-HID, CATx 1G, 4K/30 or 2x 1920x1200
OEC-SLDFSUDK1/IRK	OEC-SRDFSUDK1/IRK	S		✓		DP 1.1, USB-HID, Fiber 1G, 4K/30 or 2x 1920x1200
OEC-SLDF3UDK1/IRK	OEC-SRDF3UDK1/IRK	S		✓		DP 1.1, USB-HID, Fiber 3G, 4K/30 or 2x 1920x1200
OEC-SLD2CUDK1/IRK	OEC-SRD2CUDK1/IRK	T		✓	✓	DP 1.1, USB-HID, redundant CATx 1G, 4K/30 or 2x 1920x1200
OEC-SLD2SUDK1/IRK	OEC-SRD2SUDK1/IRK	T		✓	✓	DP 1.1, USB-HID, redundant Fiber 1G, 4K/30 or 2x 1920x1200
OEC-SLDFRUDK1/IRK	OEC-SRDFRUDK1/IRK	T		✓	✓	DP 1.1, USB-HID, redundant Fiber 3G, 4K/30 or 2x 1920x1200
DP 1.1 Plus Xtenders with dual video input, dual output						
OEC-SLDTXUDU1/IRK	OEC-SRDTXUDU1/IRK	S				DP 1.1 Plus, USB-HID, CATx 1G, 4K/30 or 2x 1920x1200
OEC-SLDFSUDU1/IRK	OEC-SRDFSUDU1/IRK	S				DP 1.1 Plus, USB-HID, Fiber 1G, 4K/30 or 2x 1920x1200
OEC-SLDF3UDU1/IRK	OEC-SRDF3UDU1/IRK	S				DP 1.1 Plus, USB-HID, Fiber 3G, 4K/30 or 2x 1920x1200
OEC-SLD2CUDU1/IRK	OEC-SRD2CUDU1/IRK	T			✓	DP 1.1 Plus, USB-HID, redundant CATx 1G, 4K/30 or 2x 1920x1200
OEC-SLD2SUDU1/IRK	OEC-SRD2SUDU1/IRK	T			✓	DP 1.1 Plus, USB-HID, redundant Fiber 1G, 4K/30 or 2x 1920x1200
OEC-SLDFRUDU1/IRK	OEC-SRDFRUDU1/IRK	T			✓	DP 1.1 Plus, USB-HID, redundant Fiber 3G, 4K/30 or 2x 1920x1200
DP 1.2 Plus Xtenders						
OEC-SLDF3UDX1/IRK	OEC-SRDF3UDX1/IRK	W				DP 1.2 Plus, USB-HID, Fiber 3G, 4K/60
OEC-SLDFRUDX1/IRK	OEC-SRDFRUDX1/IRK	X			✓	DP 1.2 Plus, USB-HID, redundant Fiber 3G, 4K/60
DP 1.2 Plus Xtenders with local video out, remote PC in						
OEC-DLDT3UDX1/IRK	OEC-DRDT3UDX1/IRK	U	✓			DP 1.2 Plus, USB-HID, CATx 3G, 4K/60, local video/PC
OEC-DLDF3UDX1/IRK	OEC-DRDF3UDX1/IRK	U	✓			DP 1.2 Plus, USB-HID, Fiber 3G, 4K/60, local video/PC
OEC-DLDT3UDX1/IRK	OEC-DRDT3UDX1/IRK	V	✓		✓	DP 1.2 Plus, USB-HID, redundant CATx 3G, 4K/60, local video/PC
OEC-SLDFRUDX1/IRK	OEC-SRDFRUDX1/IRK	V	✓		✓	DP 1.2 Plus, USB-HID, redundant Fiber 3G, 4K/60, local video/PC
DP 1.2 Plus Xtenders with local video/remote PC and Multi-Stream (MST)						
OEC-DLDT3UDM1/IRK	OEC-DRDT3UDM1/IRK	S	✓	✓		DP1.2 Plus MST, USB-HID, CATx 3G, 4K/60, Local video
OEC-DLDF3UDM1/IRK	OEC-DRDF3UDM1/IRK	S	✓	✓		DP1.2 Plus MST, USB-HID, Fiber 3G, 4K/60, Local video
OEC-DLDT3UDM1/IRK	OEC-DRDT3UDM1/IRK	T	✓	✓	✓	DP1.2 Plus MST, USB-HID, redundant CATx 3G, 4K/60, Local video
OEC-DLDFRUDM1/IRK	OEC-DRDFRUDM1/IRK	T	✓	✓	✓	DP1.2 Plus MST, USB-HID, redundant Fiber 3G, 4K/60, Local video
DP 1.2 Xtenders with JPEG-XS codec						
OEC-SLDTXUDS1/IRK	OEC-SRDTXUDS1/IRK	W				DP 1.2, USB-HID, CATx 1G, 4K/5K@60
OEC-SLDFSUDS1/IRK	OEC-SRDFSUDS1/IRK	W				DP 1.2, USB-HID, Fiber 1G, 4K/5K@60
OEC-SLD2CUDS1/IRK	OEC-SRD2CUDS1/IRK	X			✓	DP 1.2, USB-HID, redundant CATx 1G, 4K/5K@60
OEC-SLD2SUDS1/IRK	OEC-SRD2SUDS1/IRK	X			✓	DP 1.2, USB-HID, redundant Fiber 1G, 4K/5K@60
DP 1.2 Xtenders with JPEG-XS codec, local video/PC						
OEC-DLDTXUDS1W/IRK	OEC-DRDTXUDS1W/IRK	W	✓			DP 1.2, USB-HID, CATx 1G, 4K/5K@60, local video/PC
OEC-DLDFSUDS1W/IRK	OEC-DRDFSUDS1W/IRK	W	✓			DP 1.2, USB-HID, Fiber 1G, 4K/5K@60, local video/PC
OEC-DLDF3UDS1W/IRK	OEC-DRDF3UDS1W/IRK	U	✓			DP 1.2, USB-HID, Fiber 3G, 4K/5K@60, local video/PC
OEC-DLD2CUDS1W/IRK	OEC-DRD2CUDS1W/IRK	V	✓		✓	DP 1.2, USB-HID, redundant CATx 1G, 4K/5K@60, local video/PC
OEC-DLD2SUDS1W/IRK	OEC-DRD2SUDS1W/IRK	V	✓		✓	DP 1.2, USB-HID, redundant Fiber 1G, 4K/5K@60, local video/PC
OEC-DLDFRUDS1W/IRK	OEC-DRDFRUDS1W/IRK	V	✓		✓	DP 1.2, USB-HID, redundant Fiber 3G, 4K/5K@60, local video/PC

Table 7. Main card connection panels

DVI/VGA + USB-HID

	CPU - Transmitter Card	User - Receiver Card
A		
	USB-HID, DVI-D	
B		
	USB-HID, DVI-D, redundant link	
C		
	USB-HID, DVI-I/VGA	
D		
	USB-HID, DVI-I/VGA, redundant link	
E		
	USB-HID, DVI-I/VGA (full video scaling)	

HDMI + USB-HID

J		
	HDMI video only	
K		
	USB-HID, HDMI	
L		
	USB-HID, HDMI, redundant link	
M		
	USB-HID, HDMI, and local HDMI monitor	
N		
	USB-HID, HDMI, and local HDMI monitor, redundant link	
O		
	USB-HID, HDMI, KVM switch function for PC (top card is a USB option card)	

HDMI + USB-HID (continued)

	CPU - Transmitter Card	User - Receiver Card
P		
	USB-HID, HDMI, KVM switch function for PC, redundant link. (Top card is option)	
Q		
	USB-HID, HDMI 2.0, HDMI (TX-In, RX-Out), and Micro HDMI (TX-Out, RX-In)	
R		
	USB-HID, HDMI 2.0, HDMI (TX-In, RX-Out), and Micro HDMI (TX-Out, RX-In) Redundant link	

DP + USB-HID

S		
	USB-HID, DP, single-head/dual-head or local video/KVM switch	
T		
	USB-HID, DP, single-head/dual-head, or local video/KVM, redundant	
U		
	USB-HID, DP1.2 3G Fiber	
V		
	USB-HID, DP 1.2, 3G Fiber, redundant	
W		
	USB-HID, DP 1.2 XS, 3G Fiber	
X		
	USB-HID, DP 1.2 XS, 3G Fiber, redundant	

USB 2.0 HIGH SPEED

Y		
	USB 2.0 (High-speed, 480 Mbps)	

Notes:

1. VGA video on cards C and D is up to 1920x1080 or 1920x1200. Card E has OSD with full scaling capabilities.
2. Dual-link and dual-head cards F, G, H, and I use DMS-59 connectors and are supplied with a DMS-59-to-DVI-D adapter cable.
3. DP cards S and T are used for DP 1.1 and DP 1.2, with different video port descriptions.

Table 8. Part numbers for option cards when specified without chassis

TRANSMITTER	RECEIVER	Figure	Description
OEC-L1H	OEC-R1H	U1	USB-HID
OEC-L1F	OEC-R1F	U3	Embedded USB 2.0 with 4x device ports up to 100 Mbps
OEC-L1AS	OEC-R1AS	A1	Analog Audio + RS232
OEC-L1AS/115	OEC-R1AS/115	A1	Analog Audio + RS232 up to 115.2K baud
OEC-L1A422	OEC-R1A422	A1	Analog Audio + RS422
OEC-L1AS+1PS	OEC-R1AS+1PS	A2	Analog Audio + RS232 + PS/2
OEC-L1AS+1H	OEC-R1AS+1H	A3	Analog Audio + RS232 + USB-HID
OEC-L1A422+1H	OEC-R1A422+1H	A3	Analog Audio + RS422 + USB-HID
OEC-L1AS+1F	OEC-R1AS+1F	A5	Analog Audio + RS232 + embedded USB 2.0 with 4x device ports up to 100 Mbps
OEC-L1ASF/115	OEC-R1ASF/115	A5	Analog Audio + RS232 up to 115.2K baud + embedded USB 2.0 with 4x device ports up to 100 Mbps
OEC-L1A422+1F	OEC-R1A422+1F	A5	Analog Audio + RS422 + embedded USB 2.0 with 4x device ports up to 100 Mbps
OEC-L2A422	OEC-R2A422	A6	Dual Analog Audio + Dual RS422
OEC-L1DA+1F	OEC-R1DA+1F	D6	Digital Audio, S/P-DIF, Mini-XLR, TOS-L + embedded USB 2.0 with 4x device ports up to 100 Mbps
OEC-L1AB	OEC-R1AB	B1	Balanced symmetrical analog audio with phantom power, terminal block and pre-amp
OEC-L1AB+1F	OEC-R1AB+1F	B2	Balanced symmetrical analog audio with phantom power, terminal block and pre-amp + embedded USB 2.0 with 4x device ports up to 100 Mbps
Single unit cards			
	OEC-R1PB	PB	Push button for displaying OSD on receiver unit for user with no keyboard
	OEC-GPIO	G1	GPIO option with up to 8 configurable GPIO In/Out, receiver only
	OEC-GPIO+1AS	G2	GPIO option with up to 8 configurable GPIO In/Out, analog audio + RS232, receiver only
OEC-1FS		F1	Fan module, occupies 1 card slot in any chassis
OEC-SNMP-R1		SN	SNMP monitoring module, uses RJ45 Ethernet for chassis CH07 slot 5 and CH21 slot 21 only

Table 9. Option card connection panels

	CPU - Transmitter Card	User - Receiver Card
U1		
	USB HID for keyboard and mouse	
U3		
	USB2.0 embedded, 4 x USB-A device ports up to 100Mbps	
A1		
	RS-232/RS422 Serial (DB9), Analog Audio, PS/2 keyboard and mouse	
A2		
	RS-232/RS422 Serial (DB9), Analog Audio, PS2 keyboard and mouse	
A3		
	RS-232/RS422 Serial (DB9), Analog Audio, USB2.0 embedded, full speed	
A5		
	RS-232/RS422 Serial (DB9), Analog audio, USB 2.0 embedded up to 100Mbps	
A6		
	Dual analog audio + dual RS422	
B1		
	Balanced audio with terminal block and pre-amp	
B2		
	Balanced audio + USB 2.0 embedded up to 100Mbps	

	CPU - Transmitter Card	User - Receiver Card
D6		
	Digital audio, S/P-DIF, Mini-XLR, TOS-Link, USB-2.0 up to 100Mbps	
PB		
	Push button for displaying OSD on receiver unit for user with no keyboard	
G1		
	GPIO option with up to 8 GPIO In/Out, receiver only	
G2		
	GPIO option with up to 8 GPIO In/Out, RS232, analog audio, receiver only	
F1		
	FAN module. Occupies 1-card slot in any chassis	
SN		
	SNMP Module. RJ45 Ethernet and mini usb service port with two LEDs	

Notes:

1. One Main Card in an Orion chassis can support one option card. The option card is mounted above the main card in the chassis.

Figure 1. Various cards installed in two card chassis



**DVI ■ USB-HID ■ Fiber
USB 2.0 Embedded ■ Audio ■ Serial**

OR2-SRDFSUD1D/1AS+1E (top)
OT2-SLDFSUD1D/1AS+1E (bottom)



**HDMI with local video ■ USB-HID ■ CATx
Redundant +5V power supplies**

OR2-SRDTXUH1H/DP (top)
OT2-DLDTXUH1H/DP (bottom)



**DP 1.2 ■ USB HID ■ Fiber
Redundant link ■ High performance**

OR2-SRDFRUDX1 (top)
OT2-SLDFRUDX1 (bottom)



**DP 1.1 ■ USB HID ■ CATx
Redundant link**

OR2-SRD2CUDP1 (top)
OT2-SLD2CUDP1 (bottom)



DVI-I (DVI and VGA) ■ USB HID ■ CATx

OT2-SLDTXUD1V (top)
Front side of chassis (bottom)



**DP 1.1 ■ USB HID ■ Fiber
Audio ■ Serial ■ 48V DC input**

OT3-SLDFSUDP1/D48/1AS

Figure 2. Various cards installed in four card chassis



OT4-SLDFSUD3D

OR4-SRDFSUD3D

Main card: DVI ■ USB-HID ■ Fiber

Option card: None

Power option: Standard



OT4-SLDTXUH2H/2AS

OR4-SRDTXUH2H/2AS

Main card: HDMI ■ USB-HID ■ CATx

Option card: Serial ■ Audio

Power option: Redundant +5V power supplies



OT4-SLDFSUD2D/2AS+2E

OR4-SRDFSUD2D/2AS+2E

Main card: DVI ■ USB-HID ■ Fiber

Option card: USB 2.0 embedded ■ Serial ■ Audio

Power option: Standard

Figure 3. Various cards installed in six card chassis



OR6-SRDTXUH3H/3E/DP

OT6-SLDTXUH3H/3E/DP

Main card: HDMI ■ USB-HID ■ CATx

Option card: USB 2.0 embedded

Power option: IEC power and +5V redundant power



OR7-SRDFSUDP3/3AS/BPF/DP

OT7-SLDFSUDP3/3AS/BPF/DP

Main card: DP 1.1 ■ USB-HID ■ Fiber

Option card: Audio ■ Serial

Power option: Backplane with redundant IEC power, hot swappable, front mount

Figure 4. Various cards installed in 21-card chassis



Orion XTender 21 card chassis with Transmitter cards installed
4 × DVI-D/USB-HID with the audio/serial/embedded USB 2.0 option card, CATx
3 × DVI-D/USB-HID with the embedded USB 2.0 option card, CATx
7 × DVI-D/USB-HID cards, CATx



Orion XTender 21 card chassis with Transmitter cards installed
21 × DVI-D/USB-HID cards, CATx



Orion XTender 21 card chassis with fiber Transmitter cards installed (top)

8× DVI-D/USB-HID cards, fiber

Orion XTender 21 card chassis with fiber Receiver cards installed (bottom)

8× DVI-D/USB-HID cards, fiber



Orion XTender 21 card chassis – back panel

Chassis configured with optional redundant power supply and locking connectors for each power supply

WWW.ROSE.COM ■ sales@rose.com ■ (281) 933-7673

Rose Electronics ■ 10707 Stancliff Road ■ Houston, Texas 77099

Rose USA (281) 933-7673 ■ Rose Europe +49 (0) 1762 6730896

Rose Asia +65 6324 2322 ■ Rose Australia +61 (0) 421 247083

datasheet-orion-xtender-2026-05-21.pdf

 **ROSE**
ELECTRONICS
WWW.ROSE.COM